

LED EDGE-LIT EXIT SIGN

RECESSED MOUNT



GREEN OR RED LETTERING

**MIRRORED DUAL FACE OR
CLEAR SINGLE FACE**

CONFIGURABLE ARROWS

**RECESSED CEILING AND
WALL MOUNTING,
ACCESSORIES INCLUDED**

**SLEEK BRUSHED
ALUMINUM HOUSING**

**90 MINUTE BATTERY BACKUP
RUN TIME**

**TEST SWITCH AND
AC SUPPLY INDICATOR**

SUGGESTED APPLICATIONS

Commercial & Industrial,
Garages, Retail,
Schools, Hospitals

Introducing SATCO|NUVO's LED Recessed Mount Edge-Lit Exit Signs - the perfect solution for your commercial, hospitality and multi-family spaces. Available in four different configurations, these signs are designed with a sleek, brushed aluminum housing and offer configurable arrows for recessed mounting in ceilings and walls. This LED exit sign features a battery backup with a 90-minute run time, battery push-to-test button, and AC supply indicator for easy maintenance and monitoring. Choose from single face clear or dual face clear mirrored acrylic, with red or green lettering options to fit your specific needs. OSHA and NFPA compliant, don't compromise on safety - upgrade to SATCO|NUVO's LED Edge-Lit Exit Signs today.



GENERAL SPECIFICATIONS

Input Voltage, Frequency: 120/277V, 60Hz
Emergency Backup: Yes
Emergency Duration/Run Time: 90 Minutes
Recharge Time: 24 Hours
Battery Push to Test Button: Yes
Battery Type: Ni-Cad 4.8V
Recycle Time: >500

Letter Height: 6"
Letter Stroke: 3/4"
Construction: Brushed Aluminum
Mounting Options: Ceiling and Wall
Mounting Type: Recessed
Location Rating: Damp
Ambient Operating Temperature: 10°C (50°F) to 40°C (104°F)
Warranty: 2 Years



ITEM SPECIFICATIONS/ORDER INFO

Item	UPC	Watts	Input Current @120V/277V	Letter Color	Face Type	Finish/Color
67-114	045923675270	3.14W	.026/.011A	Red	Single	Clear
67-115	045923675287	2.94W	.025/.011A	Green	Dual	Mirrored
67-116	045923670251	2.94W	.025/.011A	Green	Single	Clear
67-117	045923670268	3.14W	.026/.011A	Red	Dual	Mirrored

DIMENSIONS/WEIGHTS

Item	Width (A)	Height (B)	Depth (C)	Weight (Lbs)
67-114	15.75"	11.00"	4.00"	5.20
67-115	15.75"	11.00"	4.00"	5.20
67-116	15.75"	11.00"	4.00"	5.20
67-117	15.75"	11.00"	4.00"	5.20

Recessed Ceiling Mount

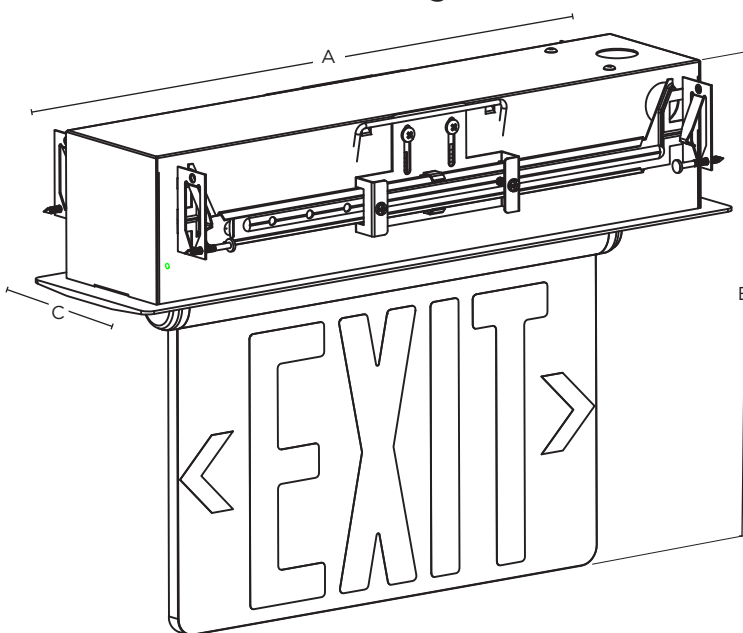

Recessed Wall Mount

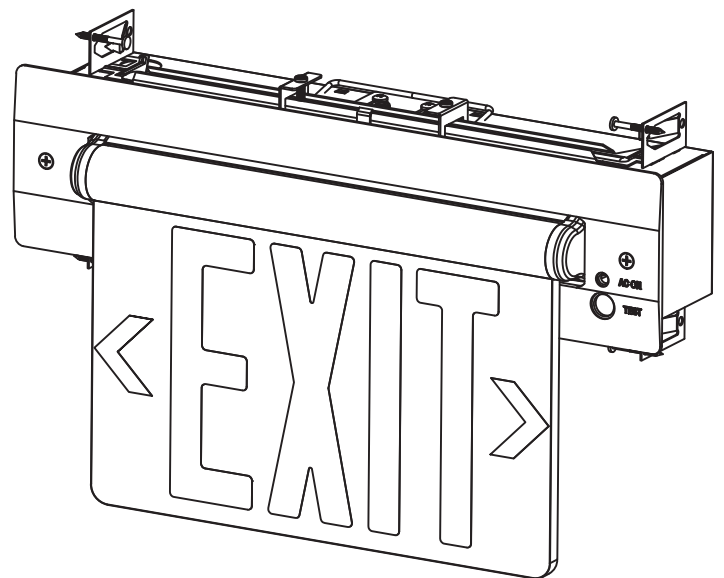

This device complies with Part 15 of the FCC Rules. Operation is subject to the following two conditions: (1) this device may not cause harmful interference, and (2) this device must accept any interference received, including interference that may cause undesired operation.

WARNING: Some products included in this specification sheet may be subject to the warning requirements of California's Proposition 65. Please refer to your product packaging for more information.

Specifications are subject to change without prior notice. Visit satco.com/service/warranty for complete 2 year warranty details.