

LED EXIT AND EMERGENCY LIGHT COMBO

NYC APPROVED



RED LETTERING

SINGLE OR DUAL FACE

**KNOCKOUT CHEVRON
DIRECTIONAL ARROWS**

**5VA FLAME RETARDANT
ABS LAMP HEADS**

**WALL OR SIDE MOUNTING,
ACCESSORIES INCLUDED**

20-GAUGE STEEL HOUSING

**90 MINUTE BATTERY BACKUP
RUN TIME**

SUGGESTED APPLICATIONS

Commercial & Industrial,
Garages, Retail,
Schools, Hospitals

Keep your building safe and secure with SATCO|NUVO's NYC Approved LED Exit and Emergency Light Combo. This top-of-the-line exit sign includes integrated emergency lights, providing ample lighting during power outages or other emergencies. With configurable knockout chevron directional arrows and NYC approved red lettering, it effectively guides occupants to safety. Its versatile mounting options (wall and side) and 20-gauge steel construction make it durable and suitable for a variety of locations. This LED exit sign features a battery backup with a 90-minute run time, battery push-to-test button, and AC supply indicator for easy maintenance and monitoring. It's also rated for damp locations and meets NYC, OSHA, and NFPA requirements keeping your building up to code.



GENERAL SPECIFICATIONS

Input Voltage, Frequency: 120/277V, 50/60Hz
Emergency Backup: Yes
Emergency Duration/Run Time: 90 Minutes
Recharge Time: 24 Hours
Battery Push to Test Button: Yes
Battery Type: Ni-Cad 3.6V
Recycle Time: >500
CCT: 5700
Letter Height: 8"
Letter Stroke: 1"

Construction: 20-Gauge Steel
Mounting Options: Wall and Side
Mounting Height: 7.5 Ft/10 Ft
Center to Center Spacing: 16 Ft/14 Ft
Path of Egress: 6 Ft
Location Rating: Damp
Ambient Operating Temperature: 10°C (50°F) to 40°C (104°F)
Warranty: 2 Years



ITEM SPECIFICATIONS/ORDER INFO

Item	UPC	Watts	Input Amps @120V/277V	Lumens	Letter Color	Face Type	Number of Lamp Heads
67-123	045923675775	3W	.025/.108A	220lm	Red	Single/Dual	2 Adjustable
67-124	045923675782	3W	.025/.108A	330lm	Red	Single/Dual	3 Adjustable

DIMENSIONS/WEIGHTS

Item	Width (A)	Height (B)	Depth (C)	Weight (Lbs)
67-123	14.56"	14.88"	2.31"	6.28
67-124	14.56"	14.88"	2.31"	6.61

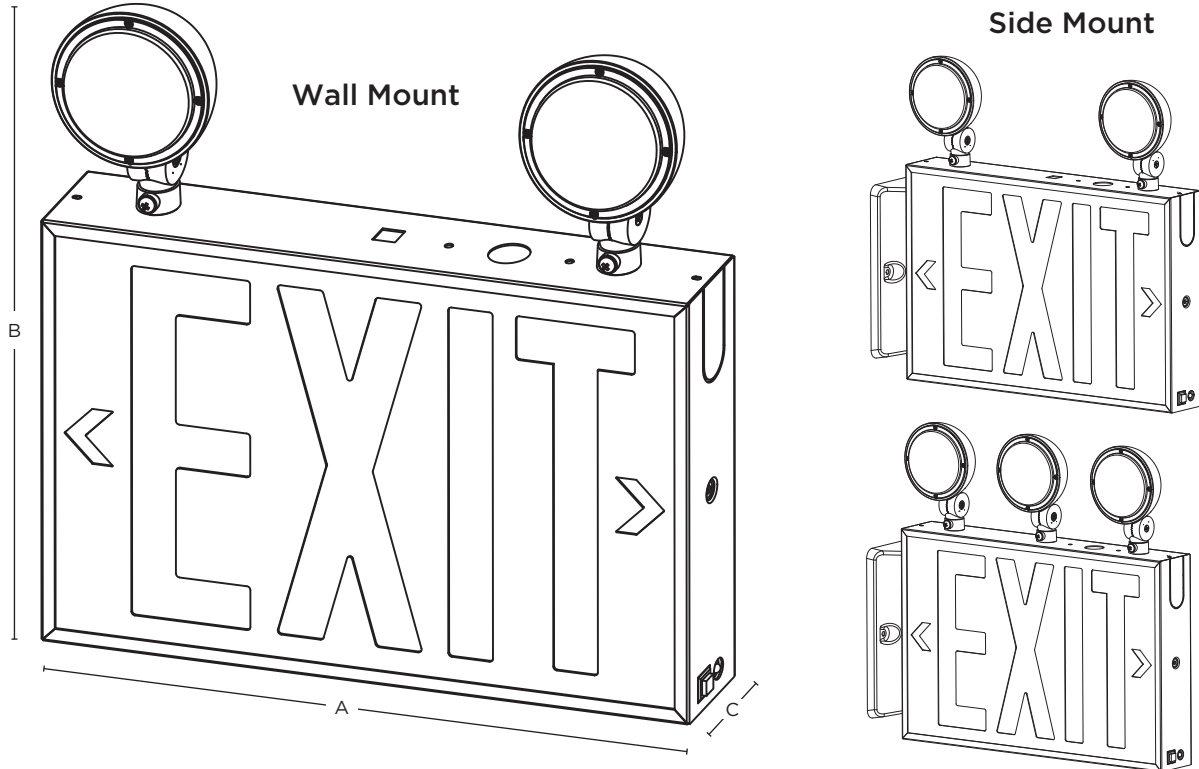

This device complies with Part 15 of the FCC Rules. Operation is subject to the following two conditions: (1) this device may not cause harmful interference, and (2) this device must accept any interference received, including interference that may cause undesired operation.

WARNING: Some products included in this specification sheet may be subject to the warning requirements of California's Proposition 65. Please refer to your product packaging for more information.

Specifications are subject to change without prior notice. Visit satco.com/service/warranty for complete 2 year warranty details.