

SMART LED TRACK HEADS

ROUND AND PINCH BACK STYLES

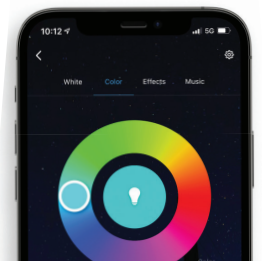

STARFISH[®]
Controlled with App



Millions of Colors



Warm to Cool Tunable White

SATCO|NUVO's LED SMART Track Heads with STARFISH[®] technology present the timeless appeal of track lighting fused with the contemporary design and conveniences of intelligent lighting. Download the STARFISH app to customize any tunable white color temperatures from 2000K warm white light to 5000K natural light or choose from millions of colors on the RGB spectrum, all from your mobile device. Available in round or pinch-back shapes, and offered in sleek black or white finishes, these track heads boast adjustability, enabling you to pivot per your lighting requirements. Experience vibrant hues, seamless control, and enchanting lighting effects tailored to your unique style and preferences with these SMART track fixtures.

COMPATIBLE WITH SATCO SINGLE
CIRCUIT H-TRACK SYSTEMS

STARFISH[®] SMART ENABLED
PRODUCT

ADVANCED PAIRING
TECHNOLOGY

RGB COLOR-CHANGING &
TUNABLE WHITE

PRE-SET AND CUSTOM
COLOR-CHANGING EFFECTS

SUGGESTED APPLICATIONS:

Showrooms, Retail,
Hospitality, Commercial,
Residential, Multi-family

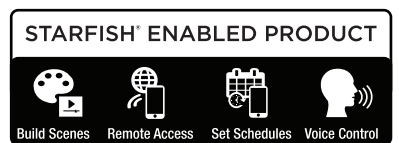

GENERAL SPECIFICATIONS

Input Voltage, Frequency: 120V, 50/60Hz

Power Factor, THD%: 0.94, 30%

Wattage: 12W

Incandescent Replacement Wattage: 60W

Input Current: 0.10A

Efficacy: 91 LPW

CCT Tunable: 2000K-5000K with STARFISH® App

RGB: Millions of colors

CRI: 80

Dimmable: Yes-only with STARFISH® App*

Lumens: 1100

Beam Angle: 36°

Functional Life: 50,000 Hours

Location Rating: Dry

Ambient Operating Temperature:-15°C (+5°F) to +50°C (+122°F)

Track Type: SATCO H-Track Compatible

Construction: Die-Cast Aluminum

Lens Material: Poly Methyl Methacrylate (PMMA)

Warranty: 3 Year



ITEM SPECIFICATIONS / ORDER INFO

Item	Finish	Shape
TH903	Matte White	Round
TH904	Matte Black	Round
TH913	Matte White	Pinch Back
TH914	Matte Black	Pinch Back

DIMENSIONS/WEIGHTS

Item	Width (A)	Length (B)	Extension (C)	Weight
TH903	5.38"	2.25"	6.38"	1.10 Lbs.
TH904	5.38"	2.25"	6.38"	1.10 Lbs.
TH913	5.91"	2.83"	5.63"	1.30 Lbs.
TH914	5.91"	2.83"	5.63"	1.30 Lbs.

OPTIONAL ACCESSORIES (SOLD SEPARATELY)

Item	Description
TP176	Offset Monopoint: Square; White Finish
TP177	Offset Monopoint: Square; Black Finish

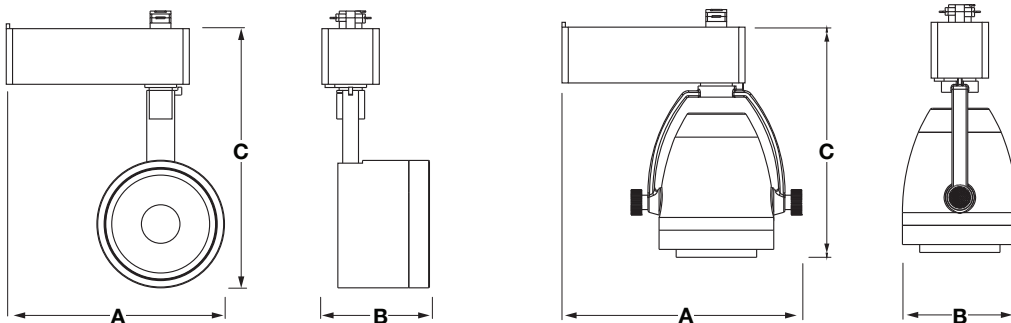

DOWNLOAD THE STARFISH APP



CONNECT
Download the STARFISH® app

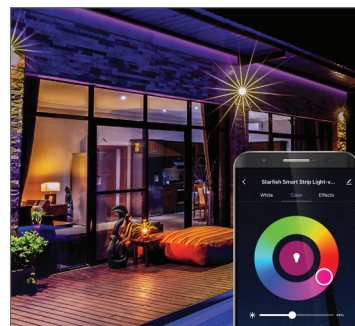

INSTALL
Pair the smart downlights and configure your settings



ENJOY
The convenience and customization of smart lighting

This device complies with Part 15 of the FCC Rules. Operation is subject to the following two conditions: (1) this device may not cause harmful interference, and (2) this device must accept any interference received, including interference that may cause undesired operation.

WARNING: Some products included in this specification sheet may be subject to the warning requirements of California's Proposition 65. Please refer to your product packaging for more information. Replacement wattage shown depends on application and fixture. Specifications are subject to change without prior notice.

* Not for use with in-wall dimmer switches.

Amazon, Alexa and all related logos are trademarks of Amazon.com, Inc. and its affiliates. Siri is a registered trademark of Apple Inc. Google, Google Play and Google Home are trademarks of Google LLC.